

ALDON Company, Inc.

MANUFACTURING EXCELLENCE SINCE 1904 IN RAILWAY AND INDUSTRIAL PRODUCTS

3410 Sunset Avenue, Waukegan, Illinois 60087 • TEL: 847-623-8800 • FAX: 847-623-6139
www.aldonco.com

Operator Instructions

CS-3X Hinged Car Stops (p/n: 4016-05-R/L)

Application

Aldon's CS-3X hinged car stops (p/n: 4016-05-R/L) allow positive stopping and/or blocking of railcars with the advantage of being easily hinged out of the way should traffic need to pass.

General Cautions

- For use with 85-141lb/yd conventional T-rail only.
- Always use in pairs.
- For use with standard size railcars only.
- Check nut tightness frequently.
- Use only ALDON replacement parts.

When Using as a Stop

- For use on flat track only.
- Car speed at impact must not exceed normal switching speed.
- Inspect stops for damage before and after each use.
- Do not power into stops with locomotive.

When Using as a Chock/Block

- 1% descending grade maximum.
- Use one pair of stops per car.
- Ease car up to stops. Do not impact.
- Apply brake and chock rear wheels.

Installation, Exposed Rail

When installing the stops note that the stops are intended to fold to the outside (field side) of the track when not in use. The four nuts should be located to the inside (gauge side) and the hinge rod to the field side. Installing the stops incorrectly can result in critical damage to the stops and ultimate failure.



ALDON Company, Inc.

MANUFACTURING EXCELLENCE SINCE 1904 IN RAILWAY AND INDUSTRIAL PRODUCTS

3410 Sunset Avenue, Waukegan, Illinois 60087 • TEL: 847-623-8800 • FAX: 847-623-6139
www.aldonco.com

To install the stops determine a suitable position free of rail defects, weld seams, and joint bars. If possible position the stop between two ties instead of centered over a tie. Drill four 1-1/16" (27mm) holes in the rail web as shown below.

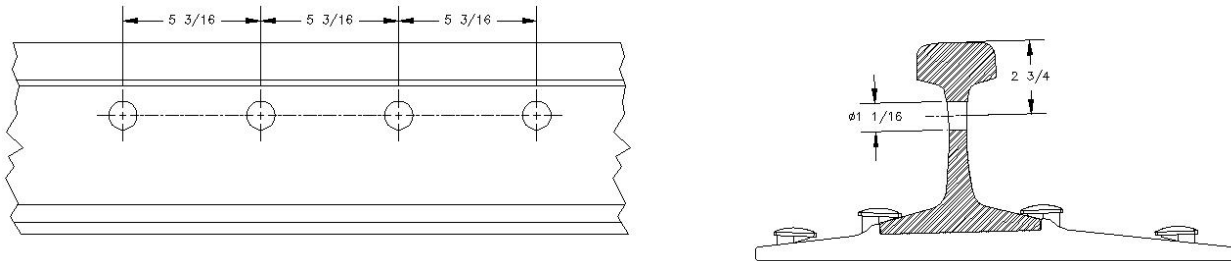

Remove the hex nuts and lock washers from the stop's studs. Install the stop into the holes with the curved face in the direction of traffic.

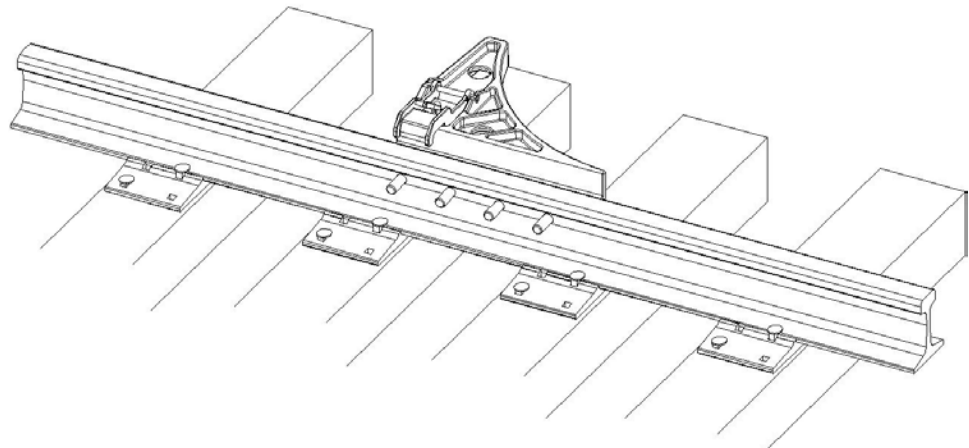

Install the spring lock washers and hex nuts. Snug all four nuts then tighten until spring lock washers are fully compressed.

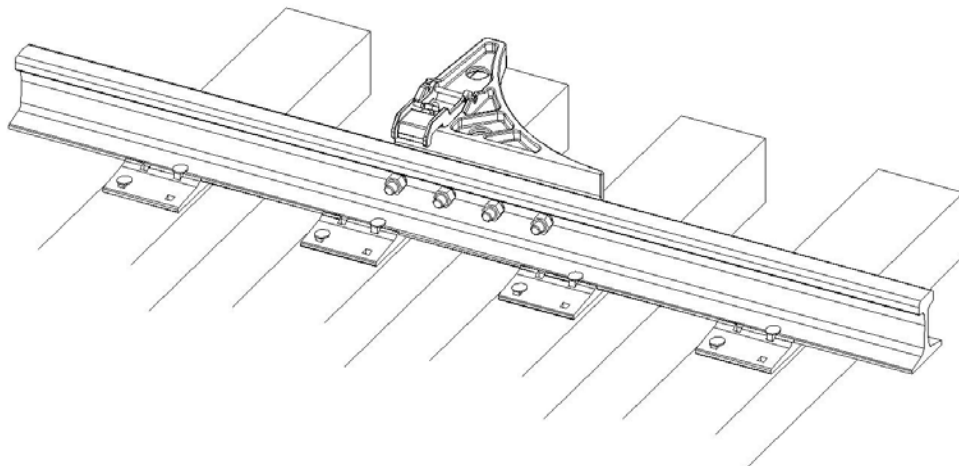

ALDON Company, Inc.

MANUFACTURING EXCELLENCE SINCE 1904 IN RAILWAY AND INDUSTRIAL PRODUCTS

3410 Sunset Avenue, Waukegan, Illinois 60087 • TEL: 847-623-8800 • FAX: 847-623-6139
www.aldonco.com

Tighten an additional 45°-90°.

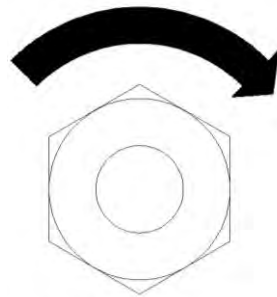

TIGHTEN UNTIL SPRING
LOCK WASHERS ARE FLAT

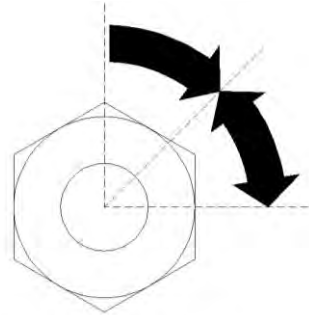

TIGHTEN ADDITIONAL
45°-90°

Installation, Flush Rail

Installation in flush rail applications requires excavation of the pavement on both field and gauge sides of the rail. The illustration below indicates the minimum recommended removal of pavement for assured operation.

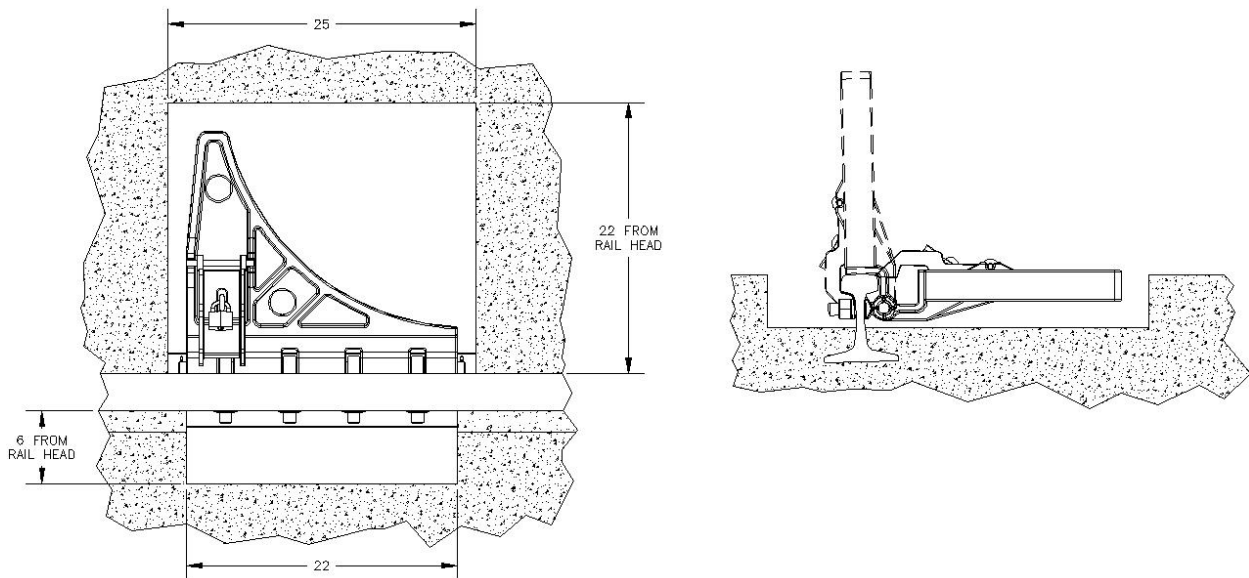

This envelope of removal should be maintained to access nuts for servicing or replacement. Once pavement is correctly excavated install same as if rail was exposed.

ALDON Company, Inc.

MANUFACTURING EXCELLENCE SINCE 1904 IN RAILWAY AND INDUSTRIAL PRODUCTS

3410 Sunset Avenue, Waukegan, Illinois 60087 • TEL: 847-623-8800 • FAX: 847-623-6139
www.aldonco.com

Operation

To use the stops remove the padlock and flip the locking casting away from the rail.

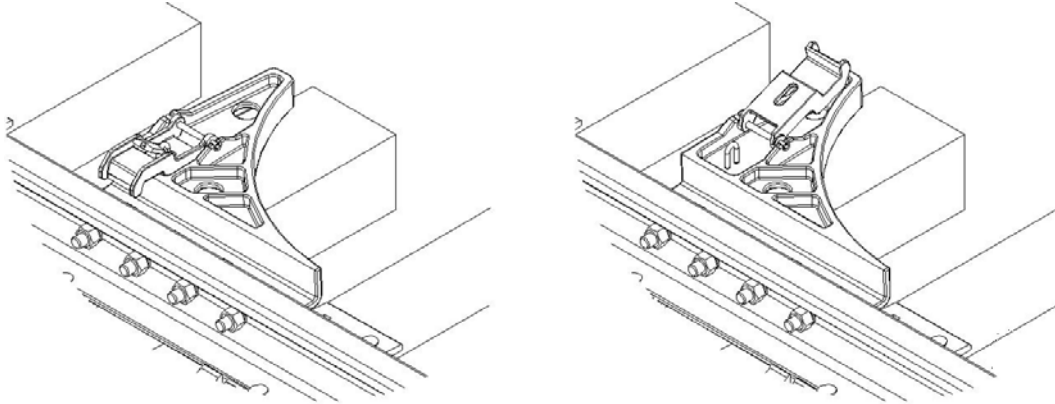

Swing stop up into place and throw locking casting over rail head. Install padlock.

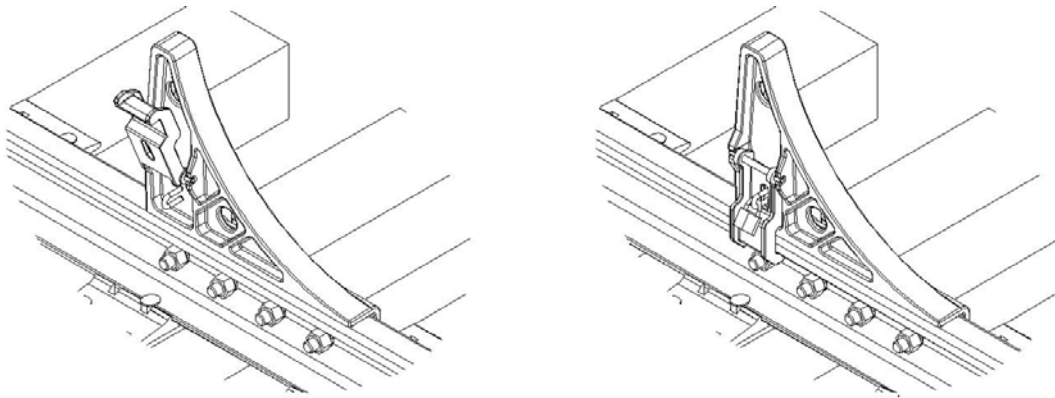

To allow traffic to bypass the stop remove the padlock and flip lock casting upward.

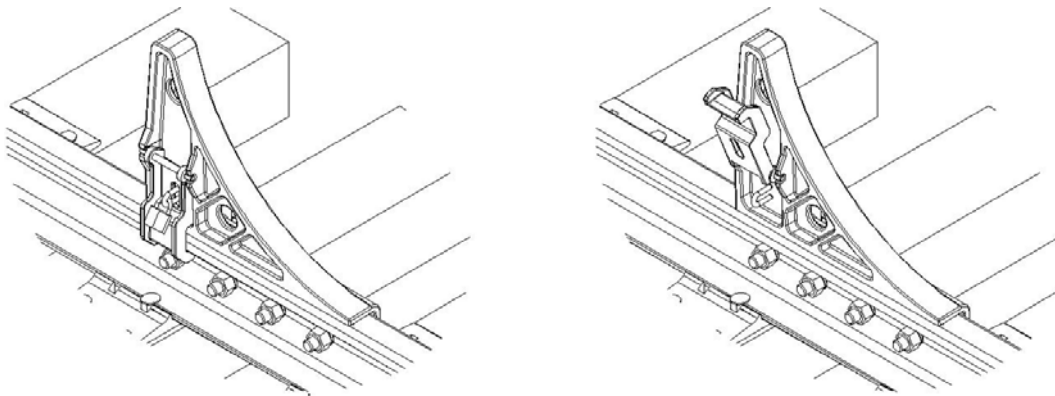

ALDON Company, Inc.

MANUFACTURING EXCELLENCE SINCE 1904 IN RAILWAY AND INDUSTRIAL PRODUCTS

3410 Sunset Avenue, Waukegan, Illinois 60087 • TEL: 847-623-8800 • FAX: 847-623-6139
www.aldonco.com

Swing the stop off the rail. Maintain control of the stop throughout the swing. Do not kick or drop the stop down.

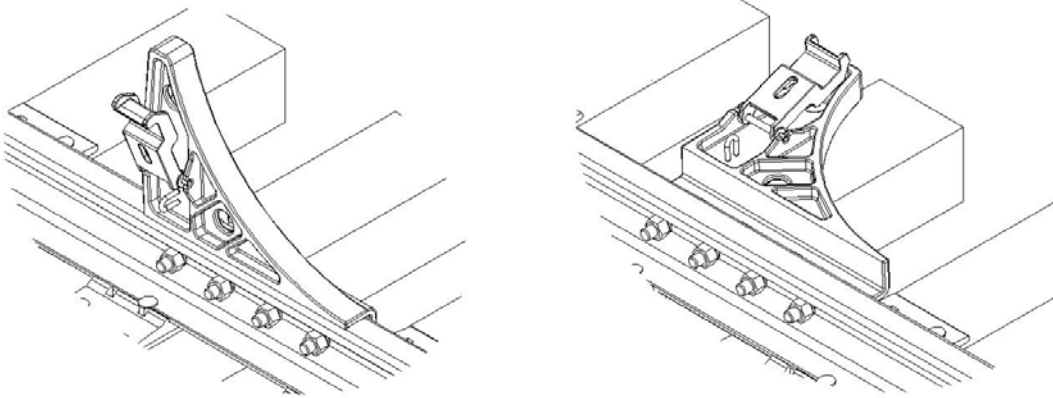

Flip lock casting back towards the rail and install padlock.

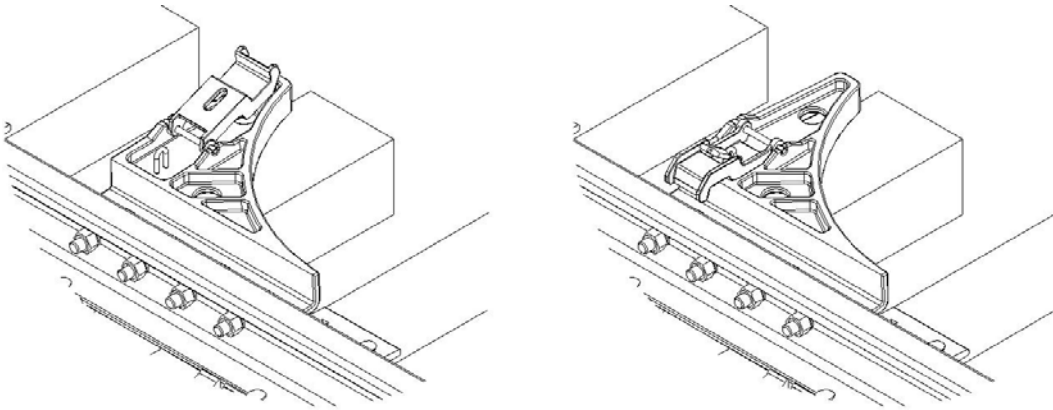

Michael R. Lannan

11-2-2011